



ACN90

Compact Indoor Corner Housing

The Moog Videolarm ACN90 housing is designed for indoor corner mount surveillance. It has a low profile, which makes this attractively styled unit ideal for offices, hallways and conference rooms. The off-white, injection-molded polycarbonate indoor housing will accept a 6" (15.2cm) maximum length camera. Each unit also features tamper resistant fasteners.

Key Features

- Attractive low profile styling
- Injection molded, off-white polycarbonate plastic
- Comes with a completely adjustable camera bracket
- Convenient cable access slots
- Tamper resistant fasteners
- Right-angle BNC connector is included to accommodate maximum camera lengths





ACN90

Is a high-impact plastic housing with clear viewing window, tamper-resistant fasteners, and camera mount with 5° - 55° tilt capabilities

CAMERA SIZE SPECIFICATIONS:

Mounting brackets are included and can accommodate most of today's popular cameras. To view the latest listing of compatible cameras please visit www.videolarm.com/thirdparty.jsp

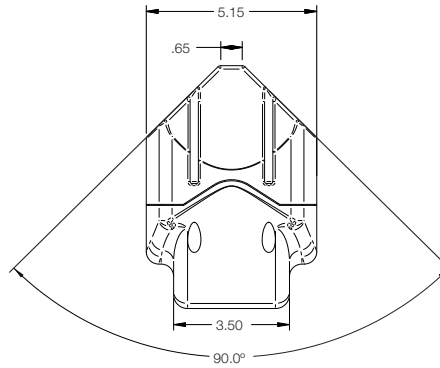

Maximum camera dimensions and lens

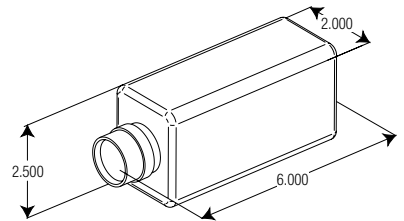
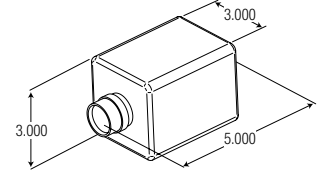

SPECIFICATIONS:

Weights

Weight:	1 Lbs.	(0.5 Kg.)
----------------	--------	-----------

Maximum Camera Length

ACN90	6.0"	(152.4mm)
--------------	------	-----------

Shipping Specifications

Model	Shipping Weight	Box Dimensions
ACN90	2 Lbs. (0.9 Kg.)	12" x 10" x 7" (305mm x 254mm x 178mm)

Architectural Drawings (ACN90)

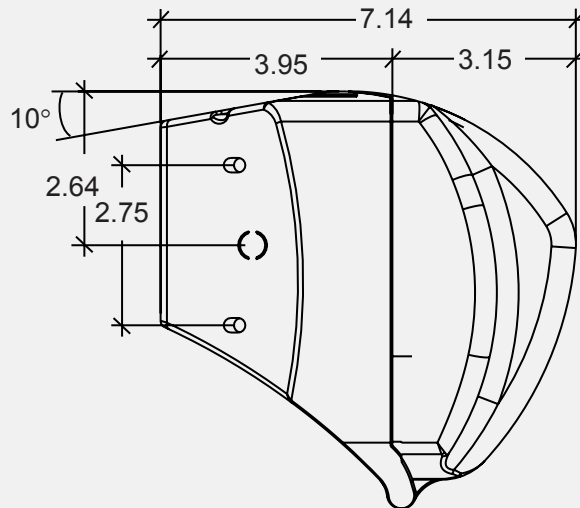
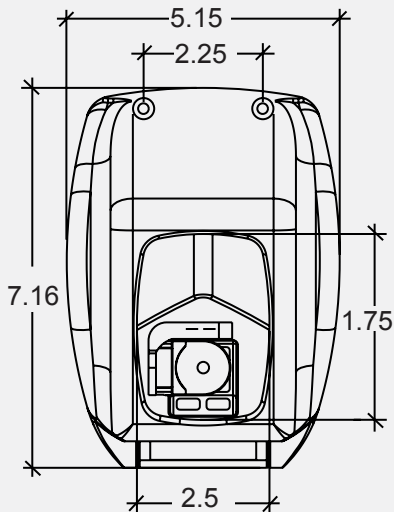

Dimensions are in inches